



2010.10

computar®

FACTORY AUTOMATION LENS

FA

[www.computar.jp](http://www.computar.jp)

# NEW PRODUCTS

## MPV series

M2518-MPV

p7



M1620-MPV



M3520-MPV

p8



M5028-MPV



### 3 megapixel C-mount lens

- Ultra low distortion (optical distortion 0.1% or less)
- Higher relative illumination rate
- Compact design (greatest dimension  $\phi$  29mm)
- Locking set screws for focus and iris
- 3 megapixel at W.D. 200mm

## MPW series

M2518-MPW

p9



## 3MP series

E1220KV

E1620KV

E2520KV

p14



### 5 megapixel C-mount lens

- Ultra low distortion (optical distortion 0.1% or less)
- Higher relative illumination rate
- Floating design

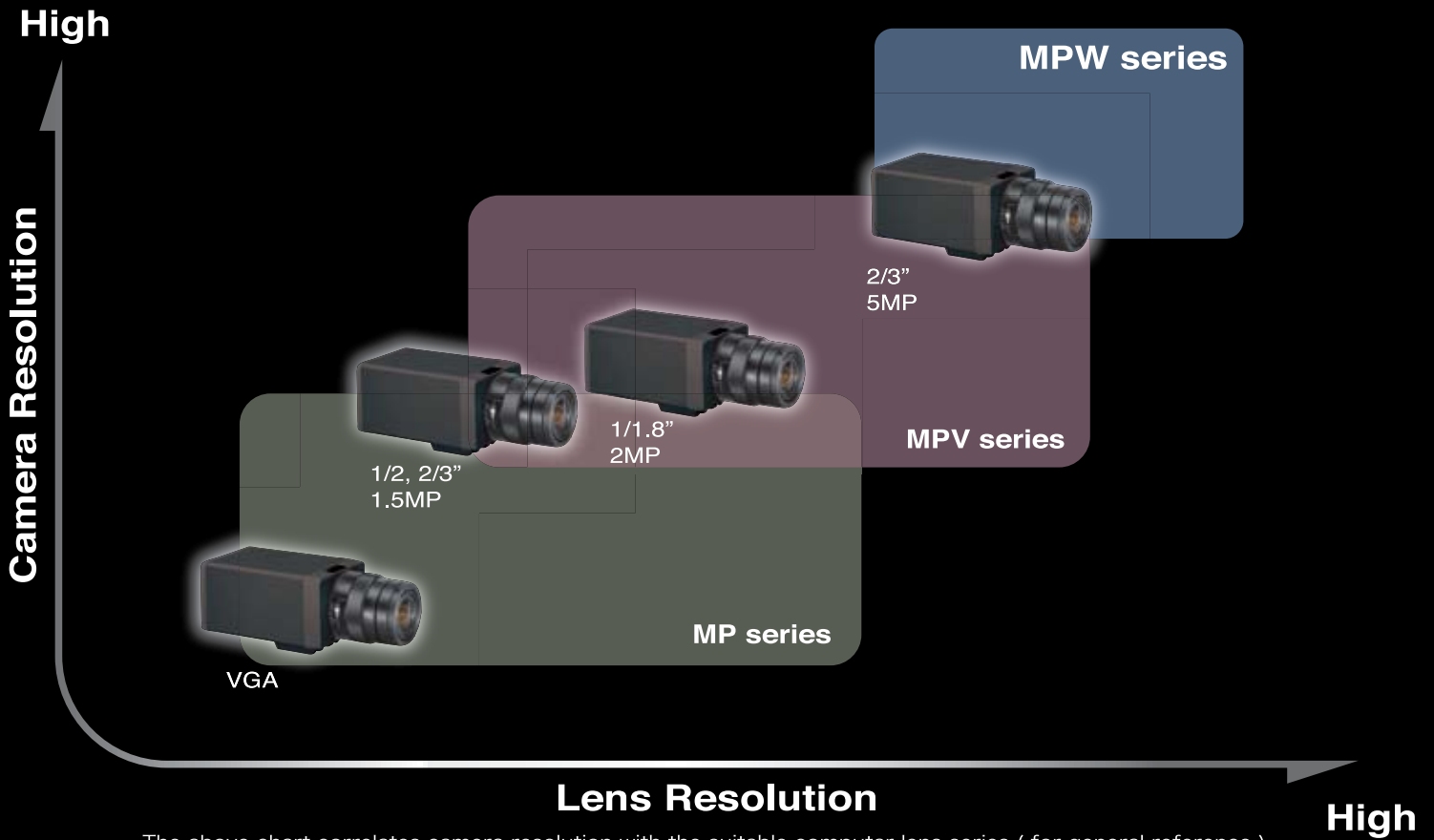
### Board mount lens

- Ultra low distortion (optical distortion 0.1% or less)
- 1/1.8" sensor
- M12, P0.5 mount
- Tough and compact design
- Optical F stop

\*Quantity commitment is necessary



## Guideline



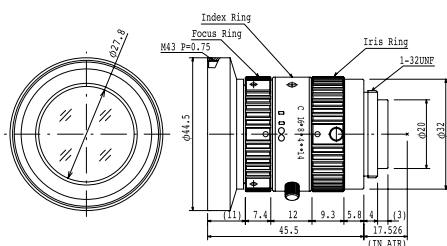
The above chart correlates camera resolution with the suitable computer lens series ( for general reference )

## CONTENTS

MP / MP2 series	03
MPV series	07
MPW series	09
MEGAPIXEL VALI-FOCAL LENS	10
MACRO ZOOM / TELECENTRIC LENS	11
MEGAPIXEL BOARD LENS	14
ACCESSORIES	16
TECHNICAL INFORMATION	17

- Captures full resolution of megapixel cameras
- Low distortion (Less than 1.0%)
- Locking set screws for focus and iris
- High contrast & sharp picture in all areas of the screen
- Compact design-Diameter 33.5mm (H0514-MP : 44.5mm)

## H0514-MP2



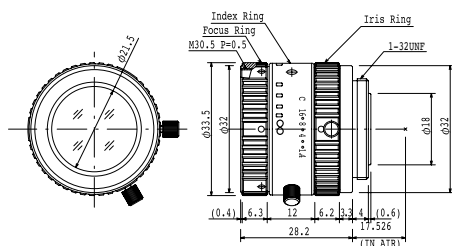
Focal Length	5mm		
Max. Aperture Ratio	1:1.4		
Max. Image Format	6.4mm x 4.8mm (φ 8mm)		
Operation Range	Iris	F1.4 - F16C	
	Focus	0.1m - 0.9m	
Control	Iris	Manual	
	Focus	Manual	
Object Dimension at M.O.D.	15.0(H)cm x 11.1(V)cm 1/2"		
Angle of View	D	76.7°	62.3°
		1/2" 65.5°	1/3" 51.4°
	V	51.4°	39.5°
Operating Temperature	-10° C ~ +50° C		

Distortion	1/2"	-0.48% (y=4.0)	1/3"	-2.26% (y=3.0)
Back Focal Length	10.8mm (WD=900mm)			
Flange Back Length	17.526mm			
Mount	C-Mount			
Filter Size	M43 P=0.75mm			
Dimensions	φ 44.5mm x 45.5mm			
Weight	102g			

Working Distance (mm)	Optical Magnification	Extension Ring (mm)	Field of View(mm)			
			1/2"		1/3"	
			H	V	H	V
900	0.006X	-	1179.8	882.3	882.3	657.2
850	0.006X	-	1115.4	834.2	834.2	621.3
800	0.006X	-	1051.0	786.0	786.0	585.4
750	0.007X	-	986.6	737.8	737.8	549.5
700	0.007X	-	922.3	689.6	689.6	513.6
650	0.008X	-	857.9	641.4	641.4	477.7
600	0.008X	-	793.5	593.2	593.2	441.8
550	0.009X	-	729.1	545.0	545.0	405.9
500	0.010X	-	664.7	496.9	496.9	370.0
450	0.011X	-	600.3	448.7	448.7	334.1
400	0.012X	-	535.9	400.5	400.5	298.2
350	0.014X	-	471.5	352.3	352.3	262.3
300	0.016X	-	407.1	304.1	304.1	226.4
250	0.019X	-	342.7	255.9	255.9	190.5
200	0.024X	-	278.4	207.8	207.8	154.6
150	0.031X	-	214.0	159.6	159.6	118.7
100	0.044X	-	149.6	111.4	111.4	82.8

Field of View = CCD Size / Optical Magnification

## M0814-MP2



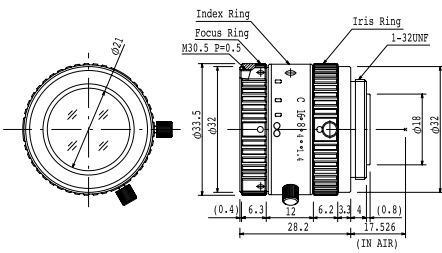
Focal Length	8mm		
Max. Aperture Ratio	1:1.4		
Max. Image Format	8.8mm x 6.6mm (φ 11mm)		
Operation Range	Iris	F1.4 - F16C	
	Focus	0.1m - Inf.	
Control	Iris	Manual	
	Focus	Manual	
Object Dimension at M.O.D.	12.1(H)cm x 9.0(V)cm 2/3"		
Angle of View	D	67.1°	51.9°
		2/3" 56.3°	1/2" 42.5°
	V	43.7°	32.4°
Operating Temperature	-10° C ~ +50° C		

Distortion	2/3"	-0.1% (y=5.5)	1/2"	-1.1% (y=4.0)
Back Focal Length	13.1mm (Inf)			
Flange Back Length	17.526mm			
Mount	C-Mount			
Filter Size	M30.5 P=0.5mm			
Dimensions	φ 33.5mm x 28.2mm			
Weight	63g			

Working Distance (mm)	Optical Magnification	Extension Ring (mm)	Field of View(mm)			
			2/3"		1/2"	
			H	V	H	V
900	0.009X	-	976.8	731.5	709.1	530.1
850	0.010X	-	923.3	691.4	670.2	501.0
800	0.010X	-	869.8	651.3	631.4	471.9
750	0.011X	-	816.3	611.2	592.5	442.8
700	0.012X	-	762.8	571.1	553.6	413.8
650	0.013X	-	709.3	531.0	514.7	384.7
600	0.014X	-	655.8	490.9	475.8	355.6
550	0.015X	-	602.3	450.8	437.0	326.5
500	0.016X	-	548.8	410.7	398.1	297.5
450	0.018X	-	495.3	370.6	359.2	268.4
400	0.020X	-	441.8	330.5	320.3	239.3
350	0.023X	-	388.3	290.4	281.4	210.2
300	0.027X	-	334.8	250.3	242.6	181.2
250	0.032X	-	281.2	210.2	203.7	152.1
200	0.039X	-	227.7	170.0	164.8	123.0
150	0.052X	-	174.2	129.9	125.9	93.9
100	0.075X	-	120.7	89.8	87.0	64.9

Field of View = CCD Size / Optical Magnification

# M1214-MP2



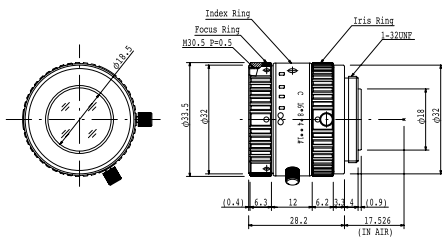
Focal Length	12mm			
Max. Aperture Ratio	1:1.4			
Max. Image Format	8.8mm x 6.6mm (φ 11mm)			
Operation Range	Iris	F1.4 - F16C		
	Focus	0.15m - Inf.		
Control	Iris	Manual		
	Focus	Manual		
Object Dimension at M.O.D.	12.1(H)cm x 9.0(V)cm 2/3"			
Angle of View	D	2/3"	49.2°	37.0°
	H		40.4°	
	V	30.8°	22.7°	
Operating Temperature	-10° C ~ +50° C			

Distortion	2/3"	-0.1% (y=5.5)	1/2"	-0.35% (y=4.0)
Back Focal Length	13.1mm (Inf)			
Flange Back Length	17.526mm			
Mount	C-Mount			
Filter Size	M30.5 P=0.5mm			
Dimensions	φ 33.5mm x 28.2mm			
Weight	62g			

Working Distance (mm)	Optical Magnification	Extension Ring (mm)	Field of View(mm)			
			2/3"		1/2"	
			H	V	H	V
900	0.013X	-	672.7	504.0	488.7	366.0
850	0.014X	-	635.9	476.4	461.9	345.9
800	0.015X	-	599.1	448.9	435.2	325.9
750	0.016X	-	562.4	421.3	408.4	305.9
700	0.017X	-	525.6	393.7	381.7	285.8
650	0.018X	-	488.8	366.1	355.0	265.8
600	0.020X	-	452.1	338.5	328.2	245.7
550	0.021X	-	415.3	311.0	301.5	225.7
500	0.023X	-	378.5	283.4	274.7	205.7
450	0.026X	-	341.7	255.8	248.0	185.6
400	0.029X	-	305.0	228.2	221.2	165.6
350	0.033X	-	268.2	200.6	194.5	145.6
300	0.038X	-	231.4	173.0	167.7	125.5
250	0.046X	-	194.7	145.5	141.0	105.5
200	0.056X	-	157.9	117.9	114.3	85.4
150	0.074X	-	121.1	90.3	87.5	65.4
100	0.106X	0.5	84.3	62.7	60.8	45.4

Field of View = CCD Size / Optical Magnification

# M1614-MP2



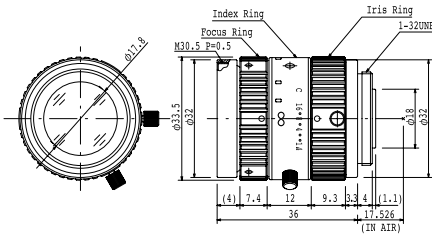
Focal Length	16mm			
Max. Aperture Ratio	1:1.4			
Max. Image Format	8.8mm x 6.6mm (φ 11mm)			
Operation Range	Iris	F1.4 - F16C		
	Focus	0.3m - Inf.		
Control	Iris	Manual		
	Focus	Manual		
Object Dimension at M.O.D.	17.2(H)cm x 12.9(V)cm 2/3"			
Angle of View	D	2/3"	38.0°	28.2°
	H		30.8°	
	V	23.4°	17.1°	
Operating Temperature	-10° C ~ +50° C			

Distortion	2/3"	-0.1% (y=5.5)	1/2"	-0.3% (y=4.0)
Back Focal Length	13.1mm (Inf)			
Flange Back Length	17.526mm			
Mount	C-Mount			
Filter Size	M30.5 P=0.5mm			
Dimensions	φ 33.5mm x 28.2mm			
Weight	60g			

Working Distance (mm)	Optical Magnification	Extension Ring (mm)	Field of View(mm)			
			2/3"		1/2"	
			H	V	H	V
900	0.018X	-	503.2	376.8	365.4	273.7
850	0.019X	-	475.6	356.2	345.3	258.6
800	0.020X	-	448.0	335.5	325.3	243.6
750	0.021X	-	420.4	314.8	305.2	228.6
700	0.023X	-	392.8	294.1	285.2	213.6
650	0.024X	-	365.2	273.4	265.1	198.5
600	0.026X	-	337.6	252.8	245.1	183.5
550	0.029X	-	310.0	232.1	225.0	168.5
500	0.031X	-	282.5	211.4	204.9	153.5
450	0.035X	-	254.9	190.7	184.9	138.4
400	0.039X	-	227.3	170.0	164.8	123.4
350	0.044X	-	199.7	149.4	144.8	108.4
300	0.052X	-	172.1	128.7	124.7	93.4
250	0.061X	0.5	144.5	108.0	104.7	78.3
200	0.076X	0.5	116.9	87.3	84.6	63.3
150	0.100X	0.5	89.3	66.6	64.6	48.3
100	0.145X	1.0	61.7	45.9	44.5	33.2

Field of View = CCD Size / Optical Magnification

# M2514-MP2



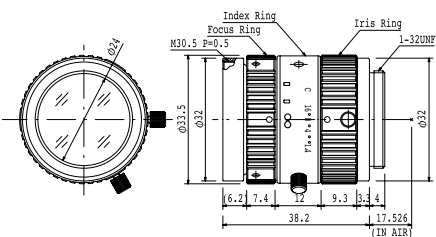
Focal Length	25mm		
Max. Aperture Ratio	1:1.4		
Max. Image Format	8.8mm x 6.6mm (φ 11mm)		
Operation Range	Iris	F1.4 - F16C	
	Focus	0.3m - Inf.	
Control	Iris	Manual	
	Focus	Manual	
Object Dimension at M.O.D.	10.6(H)cm x 7.9(V)cm 2/3"		
Angle of View	D	24.9°	18.2°
	H	2/3" 20.0°	1/2" 14.6°
	V	15.1°	11.0°
Operating Temperature	-10° C ~ +50° C		

Distortion	2/3"	-0.3% (y=5.5)	1/2"	-0.1% (y=4.0)
Back Focal Length	13.1mm (Inf)			
Flange Back Length	17.526mm			
Mount	C-Mount			
Filter Size	M30.5 P=0.5mm			
Dimensions	φ 33.5mm x 36.0mm			
Weight	71g			

Working Distance (mm)	Optical Magnification	Extension Ring (mm)	Field of View(mm)			
			2/3"		1/2"	
			H	V	H	V
900	0.028X	-	317.5	237.7	230.5	172.7
850	0.029X	-	299.9	224.5	217.7	163.1
800	0.031X	-	282.3	211.3	204.8	153.5
750	0.033X	-	264.6	198.1	192.0	143.9
700	0.036X	-	247.0	184.9	179.2	134.3
650	0.039X	-	229.4	171.6	166.4	124.7
600	0.042X	-	211.8	158.4	153.6	115.1
550	0.046X	-	194.1	145.2	140.8	105.5
500	0.050X	-	176.5	132.0	128.0	95.9
450	0.056X	-	158.9	118.8	115.2	86.3
400	0.063X	-	141.2	105.6	102.4	76.7
350	0.072X	-	123.6	92.4	89.6	67.1
300	0.084X	-	106.0	79.2	76.8	57.5
250	0.100X	0.5	88.3	66.0	63.9	47.9
200	0.126X	0.5	70.7	52.7	51.1	38.3
150	0.168X	0.5	53.0	39.5	38.3	28.7
100	0.253X	1.5	35.3	26.3	25.5	19.0

Field of View = CCD Size / Optical Magnification

# M3514-MP



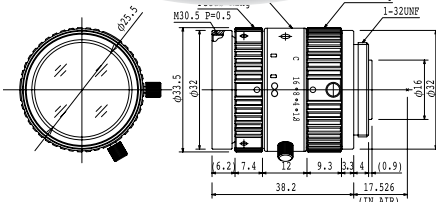
Focal Length	35mm		
Max. Aperture Ratio	1:1.4		
Max. Image Format	8.8mm x 6.6mm (φ 11mm)		
Operation Range	Iris	F1.4 - F16C	
	Focus	0.3m - Inf.	
Control	Iris	Manual	
	Focus	Manual	
Object Dimension at M.O.D.	8.1(H)cm x 6(V)cm 2/3"		
Angle of View	D	17.3°	12.6°
	H	2/3" 13.9°	1/2" 10.1°
	V	10.4°	7.6°
Operating Temperature	-10° C ~ +50° C		

Distortion	2/3"	-0.8% (y=5.5)	1/2"	-0.4% (y=4.0)
Back Focal Length	17.1mm (WD=400mm)			
Flange Back Length	17.526mm			
Mount	C-Mount			
Filter Size	M30.5 P=0.5mm			
Dimensions	φ 33.5mm x 38.2mm			
Weight	87g			

Working Distance (mm)	Optical Magnification	Extension Ring (mm)	Field of View(mm)			
			2/3"		1/2"	
			H	V	H	V
900	0.037	-	236.2	176.9	171.5	128.6
850	0.040	-	223.2	167.2	162.1	121.5
800	0.042	-	210.3	157.5	152.7	114.5
750	0.045	-	197.3	147.8	143.3	107.4
700	0.048	-	184.3	138.1	133.9	100.3
650	0.052	-	171.4	128.4	124.5	93.3
600	0.056	-	158.4	118.6	115.0	86.2
550	0.061	-	145.5	108.9	105.6	79.1
500	0.067	-	132.5	99.2	96.2	72.1
450	0.074	-	119.6	89.5	86.8	65.0
400	0.083	-	106.6	79.8	77.4	58.0
350	0.094	-	93.7	70.1	67.9	50.9
300	0.110	-	80.7	60.4	58.5	43.8
250	0.131	1	67.7	50.6	49.1	36.8
200	0.162	2	54.7	40.9	39.7	29.7
150	0.213	5	41.8	31.2	30.2	22.6
100	0.310	7	28.7	21.4	20.8	15.5

Field of View = CCD Size / Optical Magnification

# M5018-MP2

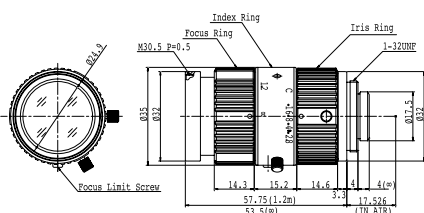


Focal Length	50mm				
Max. Aperture Ratio	1:1.8				
Max. Image Format	8.8mm x 6.6mm ( $\phi$ 11mm)				
Operation Range	Iris	F1.8 - F16C			
	Focus	0.5m - Inf.			
Control	Iris	Manual			
	Focus	Manual			
Object Dimension at M.O.D.	8.7(H)cm x 6.5(V)cm 2/3"				
Angle of View	D	13.1°		9.5°	
	H	2/3"	10.5°	1/2"	7.6°
	V		7.9°		5.7°
Operating Temperature	-10° C ~ +50° C				
Distortion	2/3"	-0.3% (y=5.5)	1/2"	-0.2% (y=4.0)	
Back Focal Length	13.1mm (Inf)				
Flange Back Length	17.526mm				
Mount	C-Mount				
Filter Size	M30.5 P=0.5mm				
Dimensions	$\phi$ 33.5mm x 38.2mm				
Weight	85g				

Working Distance (mm)	Optical Magnification	Extension Ring (mm)	Field of View(mm)			
			2/3"		1/2"	
			H	V	H	V
900	0.055X	-	160.8	120.4	116.7	87.5
850	0.058X	-	151.6	113.5	110.1	82.5
800	0.062X	-	142.4	106.6	103.4	77.5
750	0.066X	-	133.2	99.7	96.7	72.5
700	0.071X	-	124.0	92.9	90.0	67.5
650	0.077X	-	114.8	86.0	83.4	62.5
600	0.084X	-	105.6	79.1	76.7	57.5
550	0.092X	-	96.5	72.2	70.1	52.5
500	0.101X	-	87.3	65.3	63.3	47.5
450	0.113X	0.5	78.1	58.4	56.7	42.5
400	0.128X	1.5	68.9	51.6	50.0	37.5
350	0.148X	2.5	59.7	44.7	43.3	32.5
300	0.175X	3.5	50.5	37.8	36.6	27.4
250	0.214X	5.5	41.3	30.9	30.0	22.4
200	0.276X	8.5	32.1	24.0	23.3	17.4
150	0.387X	14.0	22.9	17.1	16.6	12.4
100	0.647X	26.5	13.6	10.2	9.9	7.4

Field of View = CCD Size / Optical Magnification

# M7528-MP



Focal Length	75mm				
Max. Aperture Ratio	1:2.8				
Max. Image Format	8.8mm x 6.6mm ( $\phi$ 11mm)				
Operation Range	Iris	F2.8 - F16C			
	Focus	0.3m - Inf. (※)			
Control	Iris	Manual			
	Focus	Manual			
Object Dimension at M.O.D.	4.1(H)cm x 3.1(V)cm 2/3"				
Angle of View	D	8.5°		6.2°	
	H	2/3"	6.8°	1/2"	5°
	V		5.1°		3.7°
Operating Temperature	-10° C ~ +50° C				
Distortion	2/3"	-0.4% (y=5.5)	1/2"	-0.2% (y=4.0)	
Back Focal Length	21.5mm (WD=400mm)				
Flange Back Length	17.526mm				
Mount	C-Mount				
Filter Size	M30.5 P=0.5mm				
Dimensions	$\phi$ 35mm x 57.75mm				
Weight	113g				

Working Distance (mm)	Optical Magnification	Extension Ring (mm)	Field of View(mm)			
			2/3"		1/2"	
			H	V	H	V
900	0.077	-	113.8	85.4	82.8	62.1
850	0.082	-	107.8	80.8	78.4	58.8
800	0.086	-	101.7	76.3	74.0	55.5
750	0.092	-	95.7	71.8	69.6	52.2
700	0.098	-	89.6	67.2	65.2	48.9
650	0.105	-	83.6	62.7	60.8	45.6
600	0.114	-	77.6	58.1	56.4	42.3
550	0.123	-	71.5	53.6	52.0	39.0
500	0.135	-	65.5	49.1	47.6	35.7
450	0.148	-	59.4	44.5	43.2	32.4
400	0.165	-	53.4	40.0	38.8	29.1
350	0.187	-	47.3	35.4	34.4	25.8
300	0.214	-	41.3	30.9	30.0	22.5
250	0.251	5	35.2	26.4	25.6	19.1
200	0.304	7	29.2	21.8	21.2	15.8
150	0.384	13	23.1	17.3	16.8	12.5
100	0.522	23	17.1	12.7	12.3	9.2

※Factory setting is 0.3-1.2m. Focus can be adjusted to infinity by removing "Focus Limit Screw".

Field of View = CCD Size / Optical Magnification

# 3 MEGAPIXEL ULTRA LOW DISTORTION LENSES

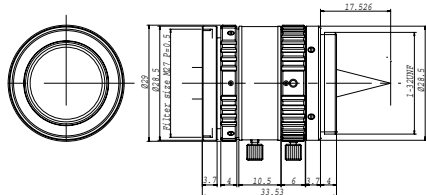
FACTORY AUTOMATION LENS

- Ultra low distortion (optical distortion 0.1% or less)
- Higher relative illumination rate
- Compact design (greatest dimension  $\phi$  29mm)

- Locking set screws for focus and iris
- 3 megapixel at W.D.200mm

**NEW**

## M1620-MPV



Focal Length	16mm						
Max. Aperture Ratio	1:2.0						
Max. Image Format	8.8mm x 6.6mm ( $\phi$ 11mm)						
Operation Range	Iris	F2.0 - F16.0					
	Focus	0.2m - Inf.					
Control	Iris	Manual					
	Focus	Manual					
Object Dimension at M.O.D.	8.8cm x 11.74cm 2/3"						
Angle of View	D		37.7°	30.1°	28.0°		
	H	2/3"	30.7°	1/1.8"	24.3°	1/2"	22.6°
	V		23.3°	18.5°		17.1°	
Operating Temperature	-10° C ~ +50° C						

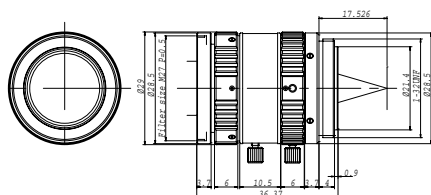
Distortion	2/3"	0.09%( $\gamma$ =5.5)	1/1.8"	-0.06%( $\gamma$ =4.32)	1/2"	-0.07%( $\gamma$ =4.0)
Back Focal Length	14.7mm (WD=300mm)					
Flange Back Length	17.526mm					
Mount	C-Mount					
Filter Size	M27.0 P=0.5mm					
Dimensions	$\phi$ 29mm x 33.53mm					
Weight	53g					

Working Distance (mm)	Optical Magnification	Extension Ring (mm)	Field of View(mm)					
			2/3"		1/1.8"		1/2"	
			H	V	H	V	H	V
900	-0.018	-	501.2	376.4	393.5	296.7	365.0	273.9
850	-0.019	-	473.8	355.8	372.0	280.5	345.1	258.9
800	-0.020	-	446.4	335.2	350.4	264.2	325.1	243.9
750	-0.021	-	418.9	314.6	328.9	248.0	305.1	228.9
700	-0.022	-	391.5	294.0	307.4	231.7	285.1	213.9
650	-0.024	-	364.1	273.4	285.8	215.5	265.2	198.9
600	-0.026	-	336.7	252.8	264.3	199.3	245.2	183.9
550	-0.028	-	309.3	232.2	242.8	183.0	225.2	168.9
500	-0.031	-	281.9	211.6	221.2	166.8	205.2	153.9
450	-0.035	-	254.5	191.0	199.7	150.5	185.2	138.9
400	-0.039	-	227.1	170.4	178.2	134.3	165.3	124.0
350	-0.044	-	199.7	149.8	156.6	118.0	145.3	109.0
300	-0.0511	-	172.2	129.2	135.1	101.8	125.3	94.0
250	-0.061	-	144.8	108.6	113.6	85.6	105.1	79.2
200	-0.075	-	117.4	88.0	92.0	69.3	85.3	64.0
150	-0.098	0.5	90.0	67.4	70.5	53.1	65.3	49.0
100	-0.142	0.5	62.5	46.8	48.9	36.8	45.4	34.0

Field of View = CCD Size / Optical Magnification

**NEW**

## M2518-MPV



Focal Length	25mm						
Max. Aperture Ratio	1:1.8						
Max. Image Format	8.8mm x 6.6mm ( $\phi$ 11mm)						
Operation Range	Iris	F1.8 - F16.0					
	Focus	0.2m - Inf.					
Control	Iris	Manual					
	Focus	Manual					
Object Dimension at M.O.D.	5.48cm x 7.31cm 2/3"						
Angle of View	D		24.6°	19.5°	18.1°		
	H	2/3"	19.9°	1/1.8"	15.7°	1/2"	14.5°
	V		15.0°	11.8°		10.9°	
Operating Temperature	-10° C ~ +50° C						

Distortion	2/3"	0.03%( $\gamma$ =5.5)	1/1.8"	-0.02%( $\gamma$ =4.32)	1/2"	-0.02%( $\gamma$ =4.0)
Back Focal Length	13.8mm (WD=300mm)					
Flange Back Length	17.526mm					
Mount	C-Mount					
Filter Size	M27.0 P=0.5mm					
Dimensions	$\phi$ 29mm x 36.37mm					
Weight	60g					

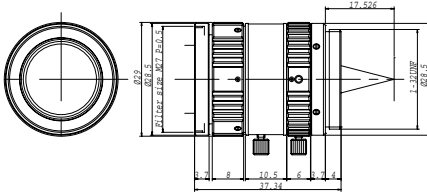
Working Distance (mm)	Optical Magnification	Extension Ring (mm)	Field of View(mm)					
			2/3"		1/1.8"		1/2"	
			H	V	H	V	H	V
900	-0.028	-	318.2	238.9	249.8	188.4	231.7	173.9
850	-0.029	-	300.7	225.8	236.0	178.0	219.0	164.3
800	-0.031	-	283.2	212.6	222.3	167.6	206.2	154.7
750	-0.033	-	265.7	199.5	208.5	157.2	193.5	145.2
700	-0.035	-	248.2	186.3	194.8	146.9	180.7	135.6
650	-0.038	-	230.7	173.2	181.0	136.5	168.0	126.0
600	-0.041	-	213.2	160.0	167.3	126.1	155.2	116.4
550	-0.045	-	195.7	146.9	153.6	115.8	142.5	106.9
500	-0.049	-	178.2	133.7	139.8	105.4	129.7	97.3
450	-0.055	-	160.7	120.6	126.1	95.0	116.9	87.7
400	-0.061	-	143.2	107.4	112.3	84.7	104.2	78.1
350	-0.070	-	125.7	94.3	98.6	74.3	91.4	68.6
300	-0.081	-	108.2	81.1	84.8	63.9	78.7	59.0
250	-0.097	-	90.7	68.0	71.1	53.5	65.9	49.4
200	-0.121	-	73.1	54.8	57.3	43.2	53.1	39.8
150	-0.159	0.5	55.6	41.6	43.5	32.8	40.4	30.3
100	-0.233	5	38.0	28.5	29.8	22.4	27.6	20.7

Field of View = CCD Size / Optical Magnification



**NEW**

# M3520-MPV



Focal Length	35mm	
Max. Aperture Ratio	1:2.0	
Max. Image Format	8.8mm x 6.6mm (φ 11mm)	
Operation Range	Iris	F2.0 - F22.0
	Focus	0.2m - Inf.
Control	Iris	Manual
	Focus	Manual
Object Dimension at M.O.D.	3.48cm x 4.63cm 2/3"	
Angle of View	D	17.8°
	H	14.3°
	V	10.7°
Operating Temperature	1/1.8"	14.0°
	1/2"	10.4°
		7.8°

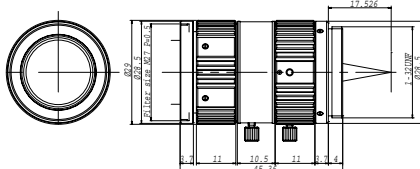
Distortion	2/3"	0.011%(γ=5.5)	1/1.8"	0.010%(γ=4.32)	1/2"	0.009%(γ=4.0)
Back Focal Length	18.0mm (WD=300mm)					
Flange Back Length	17.526mm					
Mount	C-Mount					
Filter Size	M27.0 P=0.5mm					
Dimensions	φ 29mm x 37.34mm					
Weight	59g					

Working Distance (mm)	Optical Magnification	Extension Ring (mm)	Field of View(mm)					
			2/3"		1/1.8"		1/2"	
			H	V	H	V	H	V
900	-0.040	-	221.8	166.4	174.0	131.2	161.4	121.1
850	-0.042	-	209.3	157.0	164.2	123.8	152.3	114.2
800	-0.045	-	196.7	147.6	154.3	116.3	143.2	107.4
750	-0.048	-	184.2	138.2	144.5	108.9	134.0	100.6
700	-0.051	-	171.7	128.8	134.7	101.5	124.9	93.7
650	-0.055	-	159.2	119.4	124.8	94.1	115.8	86.9
600	-0.060	-	146.6	110.0	115.0	98.7	106.7	80.0
550	-0.066	-	134.1	100.6	105.2	79.3	97.6	73.2
500	-0.072	-	121.6	91.2	95.3	71.9	88.4	66.3
450	-0.081	-	109.0	81.8	85.5	64.5	79.3	59.5
400	-0.091	-	96.5	72.4	75.7	57.0	70.2	52.7
350	-0.105	-	84.0	63.0	65.8	49.6	61.1	45.8
300	-0.123	-	71.4	53.6	56.0	42.2	52.0	39.0
250	-0.150	-	58.9	44.2	46.2	34.8	42.8	32.1
200	-0.190	-	46.3	34.8	36.3	27.4	33.7	25.3
150	-0.261	5	33.8	25.3	26.5	20.0	24.6	18.4
100	-0.417	10	21.2	15.9	16.6	12.5	15.4	11.5

Field of View = CCD Size / Optical Magnification

**NEW**

# M5028-MPV



Focal Length	50mm	
Max. Aperture Ratio	1:2.8	
Max. Image Format	8.8mm x 6.6mm (φ 11mm)	
Operation Range	Iris	F2.8 - F32.0
	Focus	0.4m - Inf.
Control	Iris	Manual
	Focus	Manual
Object Dimension at M.O.D.	4.78cm x 6.38cm 2/3"	
Angle of View	D	12.5°
	H	10.0°
	V	7.5°
Operating Temperature	1/1.8"	9.9°
	1/2"	7.3°
		5.5°

Distortion	2/3"	0.027%(γ=5.5)	1/1.8"	0.017%(γ=4.32)	1/2"	0.015%(γ=4.0)
Back Focal Length	27.7mm (WD=400mm)					
Flange Back Length	17.526mm					
Mount	C-Mount					
Filter Size	M27.0 P=0.5mm					
Dimensions	φ 29mm x 45.36mm					
Weight	69g					

Working Distance (mm)	Optical Magnification	Extension Ring (mm)	Field of View(mm)					
			2/3"		1/1.8"		1/2"	
			H	V	H	V	H	V
900	-0.058	-	151.7	113.8	118.9	89.6	110.3	82.7
850	-0.062	-	142.9	107.2	112.0	84.4	103.9	77.9
800	-0.066	-	134.1	100.6	105.1	79.2	97.5	73.1
750	-0.070	-	125.3	94.0	98.2	74.0	91.1	68.3
700	-0.075	-	116.5	87.4	91.3	68.9	84.7	63.6
650	-0.082	-	107.7	80.8	84.5	63.7	78.3	58.8
600	-0.089	-	98.9	74.2	77.6	58.5	71.9	54.0
550	-0.098	-	90.1	67.6	70.7	53.3	65.6	49.2
500	-0.108	-	81.3	61.0	63.8	48.1	59.2	44.4
450	-0.121	-	72.6	54.4	56.9	42.9	52.8	39.6
400	-0.138	-	63.8	47.8	50.0	37.7	46.4	34.8
350	-0.160	1	55.0	41.2	43.1	32.5	40.0	30.0
300	-0.191	5	46.2	34.6	36.2	27.3	33.6	25.2
250	-0.235	5	37.4	28.1	29.3	22.1	27.2	20.4
200	-0.308	10	28.6	21.5	22.4	16.9	20.8	15.6
150	-0.445	20	19.8	14.9	15.5	11.7	14.4	10.8
100	-0.801	40	11.0	8.2	8.6	6.5	8.0	6.0

Field of View = CCD Size / Optical Magnification

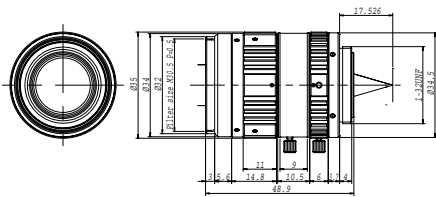
# 5 MEGAPIXEL ULTRA LOW DISTORTION LENS

FACTORY AUTOMATION LENS

- Ultra low distortion (optical distortion 0.1% or less)
- Higher relative illumination rate
- Floating design
- Locking set screws for focus and iris

**NEW**

## M2518-MPW



Focal Length	25mm	
Max. Aperture Ratio	1:1.8	
Max. Image Format	8.8mm x 6.6mm (φ 11mm)	
Operation Range	Iris	F1.8 - F16.0
	Focus	0.15m - Inf.
Control	Iris	Manual
	Focus	Manual
Object Dimension at M.O.D.	4.10cm x 5.48cm 2/3"	
Angle of View	D	25.4°
	H	20.5°
	V	15.4°
Operating Temperature	2/3"	20.1°
	1/1.8"	16.1°
	1/2"	11.3°

Distortion	2/3"	0.03%(y=5.5)	1/1.8"	-0.02%(y=4.3)	1/2"	-0.02%(y=4.0)
Back Focal Length	14.0mm (WD=300mm)					
Flange Back Length	17.526mm					
Mount	C-Mount					
Filter Size	M30.5 P=0.5mm					
Dimensions	φ 35mm x 48.90mm					
Weight	102g					

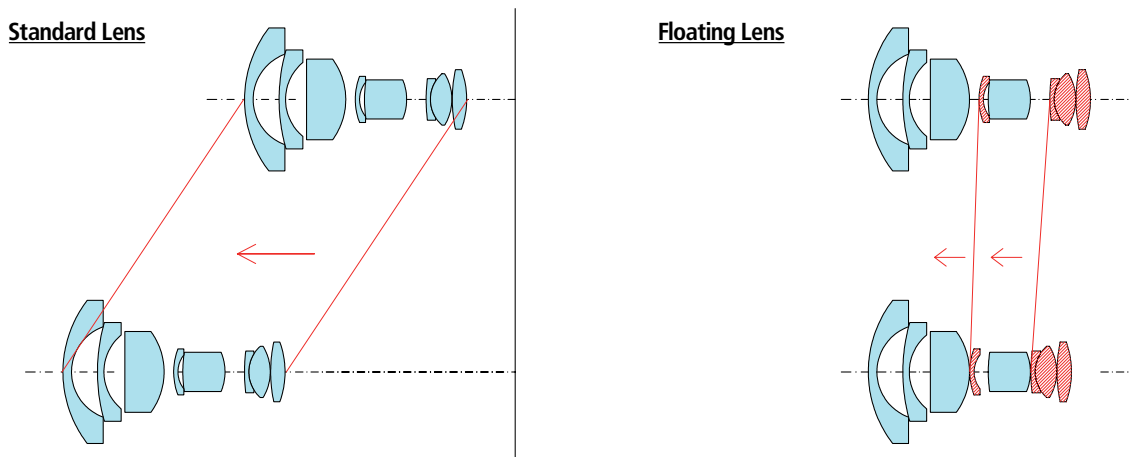
Working Distance (mm)	Optical Magnification	Extension Ring (mm)	Field of View(mm)					
			2/3"		1/1.8"		1/2"	
			H	V	H	V	H	V
900	-0.027	-	325.4	243.4	254.5	191.9	236.1	177.1
850	-0.029	-	306.2	229.9	240.3	181.2	222.9	167.3
800	-0.030	-	288.2	216.3	226.1	170.5	209.8	157.4
750	-0.033	-	270.2	202.8	212.0	159.8	196.7	147.5
700	-0.035	-	252.1	189.3	197.8	149.2	183.5	137.7
650	-0.038	-	234.1	175.7	183.7	138.5	170.4	127.8
600	-0.041	-	216.1	162.2	169.5	127.8	157.3	118.0
550	-0.044	-	198.1	148.7	155.4	117.1	144.2	108.1
500	-0.049	-	180.1	135.1	141.3	106.5	131.0	98.3
450	-0.054	-	162.1	121.6	127.1	95.8	117.9	88.5
400	-0.061	-	144.1	108.1	113.0	85.2	104.8	78.6
350	-0.070	-	126.1	94.6	98.9	74.5	91.7	68.8
300	-0.081	-	108.2	81.1	84.8	63.9	78.7	59.0
250	-0.098	-	90.3	67.7	70.8	53.3	65.6	49.2
200	-0.122	-	72.4	54.3	56.8	42.8	52.6	39.5
150	-0.161	-	54.8	41.0	42.9	32.3	39.8	29.8
100	-0.236	-	37.5	28.1	29.4	22.1	27.2	20.4

Field of View = CCD Size / Optical Magnification

### FLOATING

Basically, lens is designed to show the best performance at a certain working distance. Due to this design, a curvature of field\* is caused at other working distances, and the picture deteriorates at the corners. This curvature of field is able to be modified by a method called Floating, which makes several lens element groups move differently and controls aberration. It can provide stable picture quality from short object distances to infinity.

\*Curvature of field: Phenomenon caused by the gap of the focal point between center and corner



# MEGAPIXEL VARI-FOCAL LENS

FACTORY AUTOMATION LENS



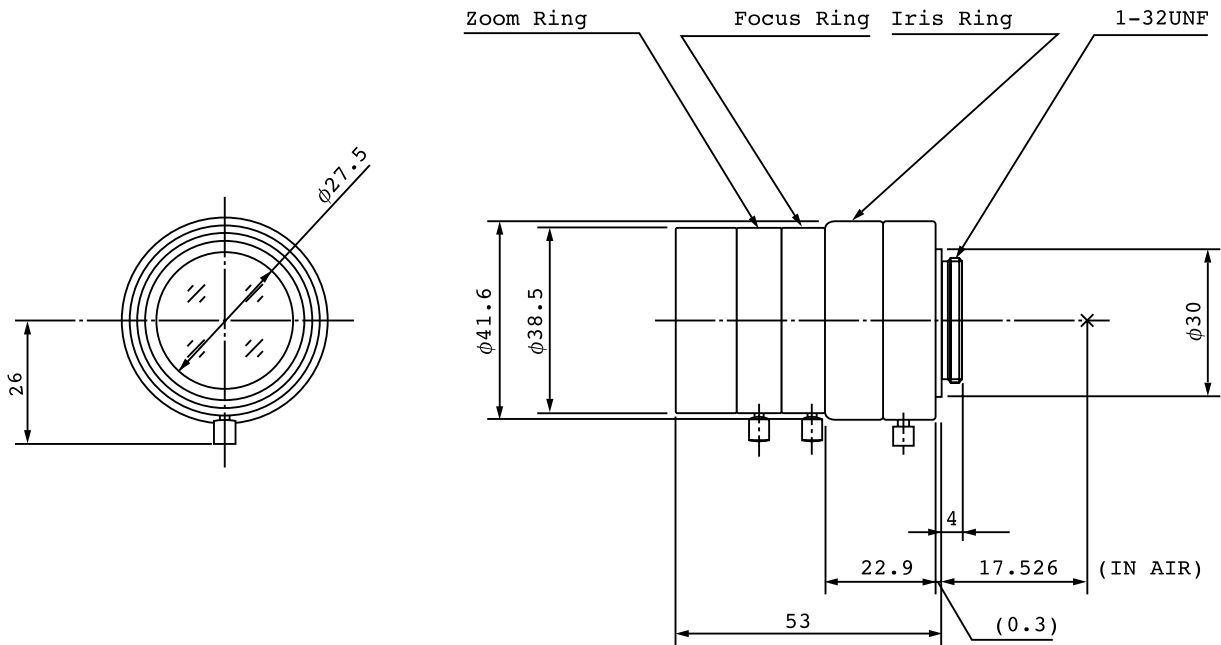
- Useful range of focal length for Factory Automation: f=12mm - 36mm
- Locking set screws for zoom, focus and iris

## M3Z1228C-MP



Focal Length	12mm - 36mm			Effective Lens Aperture	Front	φ 27.2mm			
Max. Aperture Ratio	1 : 2.8			Effective Lens Aperture	Rear	φ 12.1mm			
Max. Image Format	8.8mm x 6.6mm (φ 11 mm)			Back Focal Length	Tele	13.5mm			
Operation Range	Iris	F2.8 - F16C		Back Focal Length	Wide	14.7mm			
	Focus	0.2m - Inf.(Tele) 0.05m - Inf.(Wide)		Distortion	Tele	2/3"	+3.5% (y=5.5)	1/2"	+1.7% (y=4.0)
	Zoom	12mm-36mm							
Control	Iris	Manual		Flange Back Length	17.526mm				
	Focus	Manual		Mount	C-Mount				
	Zoom	Manual		Filter Size	M35.5 P=0.5mm				
Object Dimension at M.O.D.	12mm	4.0(H)cm x 3.0(V)cm 2/3"		Dimensions	φ 41.6mm x 53mm				
	36mm	4.8(H)cm x 3.6(V)cm 2/3"		Weight	105g				
Angle of View	D	50.4° - 16.8°	37.5° - 12.5°						
	H	2/3"	41.0° - 13.6°	1/2"	30.2° - 10.0°				
	V		31.2° - 10.4°		22.8° - 7.6°				
Operating Temperature	-10°C ~ +50°C								

※ Please note M3Z1228C-MP is produced to order



- Wide zoom range for general inspection, documentation, and visual aid applications.

## MLH-10X



Optical Magnification	0.084X - 0.84X			
Max. Magnification	0.084mm - 0.84mm			
Max. Aperture Ratio	1:5.6			
Max. Image Format	6.4mm x 4.8mm (φ 8mm)			
Operation Range	Iris	F5.6 - F32C		
	Focus	0.15m - 0.45m		
Control	Iris	Manual		
	Focus	Manual		
	Zoom	Manual		
Angle of View	D	21.6° - 4.5°	17.0° - 3.3°	13.0° - 2.5°
	H	1/2" 18.0° - 3.6°	1/3" 13.8° - 2.7°	1/4" 10.6° - 2.0°
	V	13.8° - 2.7°	10.6° - 2.0°	8.0° - 1.5°
Operating Temperature	-10° C ~ +50° C			

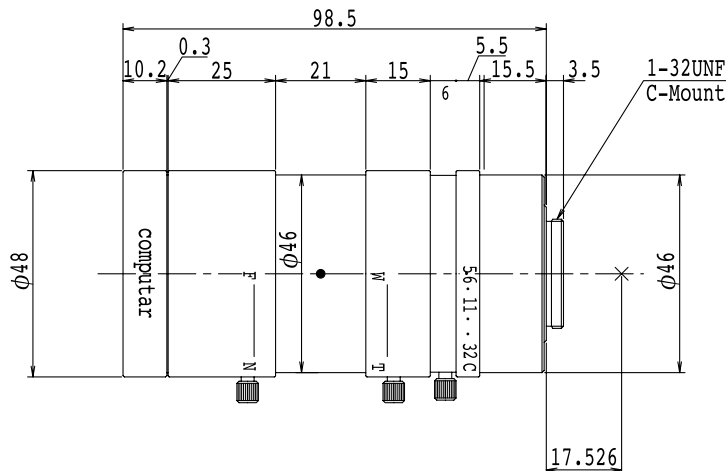
Distortion	1/2"	+0.9% at 0.084X (y=4.0) +1.6% at 0.84X (y=4.0)
Back Focal Length	23.29mm	
Flange Back Length	17.526mm	
Mount	C-Mount	
Filter Size	M46 P=0.75mm	
Dimensions	φ 48mm x 98.5mm	
Weight	260g	

Working Distance(mm)	Optical Magnification	Field of View(mm)												
		1/2"			Magnification on Monitor	1/3"			Magnification on Monitor	1/4"			Magnification on Monitor	
		H	V	D		H	V	D		H	V	D		
150	Wide	0.084X	76.2	57.1	95.2	3.73X	57.1	42.9	71.4	4.98X	42.9	32.1	53.6	6.64X
	Middle	0.19X	33.5	25.2	42.3	8.47X	25.2	18.9	31.4	11.29X	18.9	14.2	23.6	15.06X
	Tele	0.84X	7.6	5.7	9.5	37.34X	5.7	4.3	7.1	49.78X	4.3	3.2	5.4	66.38X
200	Wide	0.06X	106.7	80.0	133.3	2.67X	80.0	60.0	100.0	3.56X	60.0	45.0	75.0	4.74X
	Middle	0.13X	47.8	36.1	59.4	5.87X	36.1	27.2	44.9	7.83X	27.2	20.4	33.9	10.44X
	Tele	0.60X	10.7	8.0	13.3	26.67X	8.0	6.0	10.0	35.56X	6.0	4.5	7.5	47.41X
250	Wide	0.045X	142.2	106.7	177.8	2.00X	106.7	80.0	133.3	2.67X	80.0	60.0	100.0	3.56X
	Middle	0.101X	62.3	47.1	77.0	4.49X	47.1	35.5	58.5	5.99X	35.5	26.7	44.2	7.98X
	Tele	0.45X	14.2	10.7	17.8	20.00X	10.7	8.0	13.3	26.67X	8.0	6.0	10.0	35.56X
300	Wide	0.036X	177.8	133.3	222.2	1.60X	133.3	100.0	166.7	2.13X	100.0	75.0	125.0	2.84X
	Middle	0.082X	76.8	58.2	94.8	3.63X	58.2	43.8	72.2	4.84X	43.8	33.0	54.6	6.46X
	Tele	0.36X	17.8	13.3	22.2	16.00X	13.3	10.0	16.7	21.34X	10.0	7.5	12.5	28.45X
350	Wide	0.03X	213.3	160.0	266.7	1.33X	160.0	120.0	200.0	1.78X	120.0	90.0	150.0	2.37X
	Middle	0.069X	91.4	69.3	112.7	3.05X	69.3	52.2	85.9	4.07X	52.2	39.3	65.0	5.42X
	Tele	0.30X	21.3	16.0	26.7	13.34X	16.0	12.0	20.0	17.78X	12.0	9.0	15.0	23.71X
400	Wide	0.025X	256.0	192.0	320.0	1.11X	192.0	144.0	240.0	1.48X	144.0	108.0	180.0	1.98X
	Middle	0.06X	106.0	80.3	130.7	2.63X	80.3	60.6	99.7	3.5X	60.6	45.6	75.4	4.67X
	Tele	0.25X	25.6	19.2	32.0	11.11X	19.2	14.4	24.0	14.82X	14.4	10.8	18.0	19.76X
450	Wide	0.022X	290.9	218.2	363.6	0.98X	218.2	163.6	272.7	1.30X	163.6	122.7	204.5	1.74X
	Middle	0.05X	120.7	91.5	148.7	2.31X	91.5	69.0	113.5	3.08X	69.0	51.9	85.9	4.1X
	Tele	0.22X	29.1	21.8	36.4	9.78X	21.8	16.4	27.3	13.04X	16.4	12.3	20.5	17.38X

Field of View : Horizontal (mm) x Vertical (mm) x Diagonal (mm)

Monitor Magnification on 14inch Monitor

Magnification on Monitor = Optical Magnification x Monitor Size / CCD Size





# MEGAPIXEL MACRO ZOOM LENS

FACTORY AUTOMATION LENS

MACRO ZOOM

- Captures full resolution of mega-pixel cameras
- High contrast & sharp picture in all areas of the screen
- Compact design-Diameter 36.5mm
- Locking set screws for zoom, focus, and iris
- Low distortion
- High resolution macro zoom lens
- 3.3X magnification
- Attachment of fiber ring light can be installed (Ring Guide: M34 P=0.5)

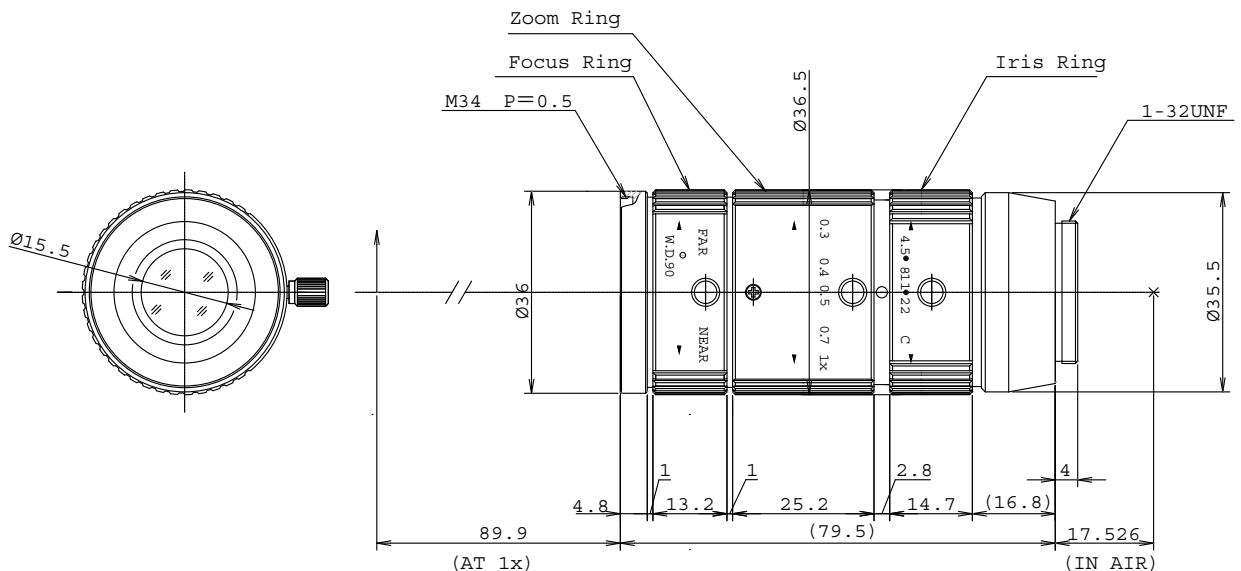
## MLM-3XMP



Max. Magnification	0.3X - 1.0X			Distortion	2/3"	+0.12% at 0.3X (y=5.5)	1/2"	-0.12% at 0.3X (y=4.0)	
Max. Aperture Ratio	1:4.5					+1.78% at 1.0X (y=5.5)		+0.77% at 1.0X (y=4.0)	
Max. Image Format	8.8mm x 6.6mm (φ 11mm)			Back Focal Length	20.4mm				
Operation Range	Iris	F4.5 - F22C			Flange Back Length	17.526mm			
	Focus	90mm			Mount	C-Mount			
Control	Iris	Manual			Filter Size	M34 P=0.5mm			
	Focus	Manual			Dimensions	φ 36.5mm x 79.5mm			
	Zoom	Manual			Weight	150g			
Angle of View	D	2/3"	14.88° - 2.84°	1/2"	10.70° - 2.72°				
	H		11.80° - 2.78°		8.48° - 2.18°				
	V	8.74° - 2.24°	6.38° - 1.64°						
Operating Temperature	-10° C ~ +50° C								

Monitor Magnification on 14inch Monitor  
Working Distance: 90mm  
Magnification on Monitor = Optical Magnification x Monitor Size / CCD Size

Optical Magnification	Field of View(mm)											
	2/3"			Magnification on Monitor	1/2"			Magnification on Monitor	1/3"			Magnification on Monitor
	H	V	D		H	V	D		H	V	D	
0.3X	29.3	22.0	36.7	9.7X	21.3	16.0	26.7	13.3X	16.0	12.0	20.0	17.8X
0.4X	22.0	16.5	27.5	12.9X	16.0	12.0	20.0	17.8X	12.0	9.0	15.0	23.7X
0.5X	17.6	13.2	22.0	16.2X	12.8	9.6	16.0	22.2X	9.6	7.2	12.0	29.6X
0.6X	14.7	11.0	18.3	19.4X	10.7	8.0	13.3	26.7X	8.0	6.0	10.0	35.6X
0.7X	12.6	9.4	15.7	22.6X	9.1	6.9	11.4	31.1X	6.9	5.1	8.6	41.5X
0.8X	11.0	8.3	13.8	25.9X	8.0	6.0	10.0	35.6X	6.0	4.5	7.5	47.4X
0.9X	9.8	7.3	12.2	29.1X	7.1	5.3	8.9	40.0X	5.3	4.0	6.7	53.3X
1.0X	8.8	6.6	11.0	32.3X	6.4	4.8	8.0	44.5X	4.8	3.6	6.0	59.3X



# TELECENTRIC LENS

FACTORY AUTOMATION LENS

- Very low distortion compared to standard macro lenses
- Wide depth of field
- Working distance: 140mm - Infinity
- Suitable for use as a telephoto lens and macro lens
- Fast F2.8 F-stop at Infinity

## TEC-M55



Focal Length	55mm
Max. Aperture Ratio	1:2.8
Max. Image Format	8.8mm x 6.6mm (φ 11mm)
Operation Range	Iris F2.8 - F32C Focus 0.14m - Inf.
Magnification	Inf. - 0.5X (Max 1.0X at 140mm with 2X Converter)
Relative Illumination	78.5% (at 0.5X)
Depth of Field	1/2" 3.5mm(at 0.5X F2.8), 6.0mm(at 0.5X F5.6)
Control	Iris Manual Focus Manual
Object Dimension at M.O.D	1.7(H)cm x 1.3(V)cm 2/3"
Operating Temperature	-10° C ~ +50° C

Distortion	2/3"	+0.2% at 0.2X (y=5.5) +0.6% at 0.5X (y=5.5)	1/2"	+0.1% at 0.2X (y=4.0) +0.3% at 0.5X (y=4.0)
	Back Focal Length	29.8mm		
Flange Back Length	17.526mm			
Mount	C-Mount			
Filter Size	M43 P=0.75mm			
Dimensions	φ 53.0mm x 92.9mm (Max. at 0.5X)			
Weight	320g			

TEC-M55

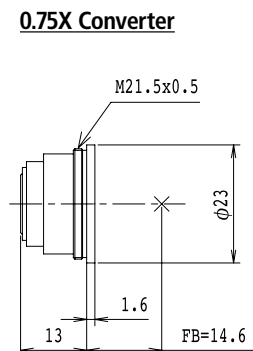
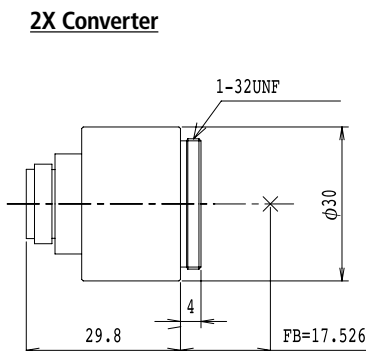
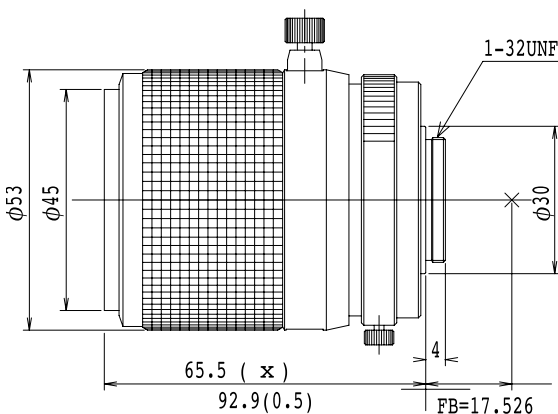
Working Distance (mm)	Optical Magnification	Field of View(mm)					
		2/3"		1/2"		1/3"	
		H	V	H	V	H	V
5000	0.011X	796.2	597.8	579.7	435.0	435.0	326.3
4000	0.014X	636.1	477.6	463.1	347.5	347.5	260.7
3000	0.018X	476.0	357.4	346.6	260.1	260.1	195.1
2000	0.028X	315.9	237.2	230.0	172.6	172.6	129.5
1500	0.037X	235.9	177.1	177.1	128.9	128.9	96.7
1000	0.056X	155.8	117.0	113.4	85.1	85.1	63.9
950	0.059X	147.8	111.0	107.6	80.7	80.7	60.6
900	0.063X	139.8	105.0	101.8	76.4	76.4	57.3
850	0.067X	131.8	99.0	96.0	72.0	72.0	54.0
800	0.071X	123.8	92.9	90.1	67.6	67.6	50.7
750	0.076X	115.8	86.9	84.3	63.2	63.2	47.4
700	0.081X	107.8	80.9	78.5	58.9	58.9	44.2
650	0.088X	99.8	74.9	72.6	55.5	54.5	40.9
600	0.096X	91.8	68.9	66.8	50.1	50.1	37.6
550	0.105X	83.8	62.9	61.0	45.8	45.8	34.3
500	0.116X	75.8	56.9	55.2	41.4	41.4	31.0
450	0.130X	67.8	50.9	49.3	37.0	37.0	27.8
400	0.147X	59.8	44.9	43.5	32.6	32.6	24.5
350	0.170X	51.8	38.8	37.7	28.3	28.3	21.2
300	0.201X	43.8	32.8	31.8	23.9	23.9	17.9
250	0.246X	35.7	26.8	26.0	19.5	19.5	14.6
200	0.317X	27.7	20.8	20.2	15.1	15.1	11.4
150	0.446X	19.7	14.8	14.3	10.8	10.8	8.1
140	0.486X	18.1	13.6	13.2	9.9	9.9	7.4

TEC-M55 with 0.75X Converter

Working Distance (mm)	Optical Magnification	Field of View(mm)					
		2/3"		1/2"		1/3"	
		H	V	H	V	H	V
5000	0.008X	1066.2	797.6	773.3	579.2	579.2	434.0
4000	0.010X	851.9	637.3	617.8	462.7	462.7	346.8
3000	0.014X	637.6	476.9	462.4	346.3	346.3	259.5
2000	0.021X	423.2	316.6	306.9	229.9	229.9	172.3
1500	0.028X	316.1	236.4	229.2	171.7	171.7	128.6
1000	0.423X	208.9	156.2	151.5	113.4	113.4	85.0
950	0.045X	198.2	148.2	143.7	107.6	107.6	80.6
900	0.047X	187.4	140.2	135.9	101.8	101.8	76.3
850	0.050X	176.7	132.2	128.1	96.0	96.0	71.9
800	0.053X	166.0	124.2	120.4	90.1	90.1	67.5
750	0.057X	155.3	116.1	112.6	84.3	84.3	63.2
700	0.061X	144.6	108.1	104.8	78.5	78.5	58.8
650	0.066X	133.8	100.1	97.0	72.7	72.7	54.5
600	0.072X	123.1	92.1	89.3	66.8	66.8	50.1
550	0.079X	112.4	84.1	81.5	61.0	61.0	45.7
500	0.087X	101.7	76.0	73.7	55.2	55.2	41.4
450	0.097X	90.9	68.0	65.9	49.4	49.4	37.0
400	0.110X	80.2	60.0	58.2	43.6	43.6	32.6
350	0.127X	69.5	52.0	50.4	37.7	37.7	28.3
300	0.151X	58.7	43.9	42.6	31.9	31.9	23.9
250	0.184X	48.0	35.9	34.8	26.1	26.1	19.5
200	0.238X	37.3	27.9	27.0	20.2	20.2	15.2
150	0.334X	26.5	19.8	19.2	14.4	14.4	10.8
140	0.363X	24.4	18.2	17.7	13.2	13.2	9.9

TEC-M55 with 2X Converter

Working Distance (mm)	Optical Magnification	Field of View(mm)					
		2/3"		1/2"		1/3"	
		H	V	H	V	H	V
5000	0.019X	453.1	340.3	330.0	247.7	247.7	185.8
4000	0.024X	362.0	271.9	263.6	197.9	197.9	148.5
3000	0.032X	270.9	203.4	197.3	148.1	148.1	111.1
2000	0.049X	179.8	135.0	130.9	98.3	98.3	73.7
1500	0.065X	134.3	100.8	97.8	73.4	73.4	55.0
1000	0.098X	88.7	66.6	64.6	48.5	48.5	36.4
950	0.104X	84.1	63.2	61.3	46.0	46.0	34.5
900	0.110X	79.6	59.8	58.0	43.5	43.5	32.6
850	0.116X	75.0	56.3	54.6	41.0	41.0	30.8
800	0.124X	70.5	52.9	51.3	38.5	38.5	28.9
750	0.133X	65.9	49.5	48.0	36.0	36.0	27.0
700	0.142X	61.4	46.1	44.7	33.5	33.5	25.2
650	0.154X	56.8	42.7	41.4	31.0	31.0	23.3
600	0.167X	52.3	39.2	38.1	28.6	28.6	21.4
550	0.183X	47.7	35.8	34.7	26.1	26.1	19.6
500	0.203X	43.2	32.4	31.4	23.6	23.6	17.7
450	0.227X	38.6	29.0	28.1	21.1	21.1	15.8
400	0.257X	34.0	25.6	24.8	18.6	18.6	14.0
350	0.297X	29.5	22.1	21.5	16.1	16.1	12.1
300	0.352X	24.9	18.7	18.2	13.6	13.6	10.2
250	0.431X	20.4	15.3	14.8	11.1	11.1	8.4
200	0.558X	15.8	11.9	11.5	8.7	8.7	6.5
150	0.789X	11.3	8.5	8.2	6.2	6.2	4.6
140	0.861X	10.4	7.8	7.6	5.7	5.7	4.3



# MEGAPIXEL BOARD LENSES

FACTORY AUTOMATION LENS



- M12 P0.5 mount
- Compact design for board camera
- Manual Iris lineup for the best combination with lighting



Megapixel Board Lenses

No.	Model Name	Format Inch	Mount	Pitch	Focal Length(mm)	Aperture (F)	Distortion	Angle of view at INF(degrees)			Angle of view at INF(degrees)			Angle of view at INF(degrees)			Iris	
								1/2"			1/3"			1/4"			No Iris	Manual
								D	H	V	D	H	V	D	H	V		
1	H0320KP	1/2	M12	0.5	3mm	F2.0	-37.5%	125.3	104.3	80.5	98.6	80.5	61.3	75.8	61.3	46.3	○	
2	HM0320KP	1/2	M12	0.5	3mm	F2.0	-37.5%	125.3	104.3	80.5	98.6	80.5	61.3	75.8	61.3	46.3		○
3	H0624KP	1/2	M12	0.5	6mm	F2.4	-9.0%	72.5	59.1	45.0	55.6	45.0	34.0	42.3	34.0	25.6	○	
4	HM0624KP	1/2	M12	0.5	6mm	F2.4	-9.0%	72.5	59.1	45.0	55.6	45.0	34.0	42.3	34.0	25.6		○
5	H0924KP	1/2	M12	0.5	9mm	F2.4	-1.6%	48.6	39.6	30.1	37.3	30.1	22.7	28.3	22.7	17.1	○	
6	HM0924KP	1/2	M12	0.5	9mm	F2.4	-1.6%	48.6	39.6	30.1	37.3	30.1	22.7	28.3	22.7	17.1		○
7	H1620KP	1/2	M12	0.5	16mm	F2.0	0.4%	27.9	22.6	17.0	21.2	17.0	12.8	16.0	12.8	9.6	○	
8	HM1620KP	1/2	M12	0.5	16mm	F2.0	0.4%	27.9	22.6	17.0	21.2	17.0	12.8	16.0	12.8	9.6		○
9	H2520KP	1/2	M12	0.5	25mm	F2.0	1.0%	18.0	14.5	10.9	13.6	10.9	8.2	10.3	8.2	6.2	○	
10	HM2520KP	1/2	M12	0.5	25mm	F2.0	1.0%	18.0	14.5	10.9	13.6	10.9	8.2	10.3	8.2	6.2		○

# 3 MEGAPIXEL ULTRA LOW DISTORTION BOARD LENSES

FACTORY AUTOMATION LENS



- Ultra low distortion (optical distortion 0.1% or less)
- 1/1.8" sensor
- M12, P0.5 mount
- Tough and compact design
- Optional F stop

\*Quantity commitment is necessary



3 Megapixel Board Lenses

No.	Model Name	Format Inch	Mount	Pitch	Focal Length(mm)	Aperture (F)	Distortion	Angle of view at INF(degrees)			Angle of view at INF(degrees)			Angle of view at INF(degrees)			Iris	
								1/1.8"			1/2"			1/3"			No Iris	Manual
								D	H	V	D	H	V	D	H	V		
1	E1220KV	1/1.8	M12	0.5	12.0mm	F2.0	0.04%	39.5	32.1	24.4	36.8	29.8	22.6	28.1	22.6	17.1	○	
2	E1620KV	1/1.8	M12	0.5	16.0mm	F2.0	-0.07%	30.0	24.3	18.4	27.9	22.6	17.0	21.2	17.0	12.8	○	
3	E2520KV	1/1.8	M12	0.5	25.0mm	F2.0	0.02%	19.5	15.7	11.9	18.1	14.6	11.0	13.7	11.0	8.2	○	



# MEGAPIXEL FISHEYE BOARD LENS

FACTORY AUTOMATION LENS



H1328KP

Megapixel Fisheye Board Lens

No.	Model Name	Format inch	Mount	Pitch	Focal Length(mm)	Aperture (F)	Distortion	Angle of view at INF(degrees)			Angle of view at INF(degrees)			Angle of view at INF(degrees)			Iris	
								1/2"			1/3"			1/4"			No Iris	Manual
								D	H	V	D	H	V	D	H	V		
1	H1328KP	1/2	M12	0.5	1.3mm	F2.8	-99.4%	180.0	180.0	151.0	177.3	151.0	117.6	○				

Image for angle of view for 1/2" Fisheye Board Lens

1/2"			1/3"			1/4"											
D	H	V	D	H	V	D	H	V									
180.0			180.0			151.0			177.3			151.0			117.6		

Rectangles show CCD size and image area on a monitor.

## FEATURES OF H1328KP

H1328KP is 180 °wide angle lens with megapixel resolution. Compared with a standard fisheye lens, H1328KP has less distortion and compression at corner, and is easy to recognize objects.

### For wide area surveillance or teleconference system

Fisheye Lens f=1.3mm (angle 180°)



view of standard wide angle lens

Standard wide angle lens f=3.3mm (horizontal angle 104.3°)



### For internal inspection of pipe and container

H1328KP has large depth of field and is suitable for internal inspection of pipe or container. This megapixel lens can also be used with high resolution cameras.

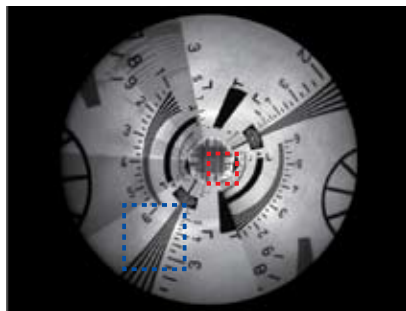


sample of pipe inspection

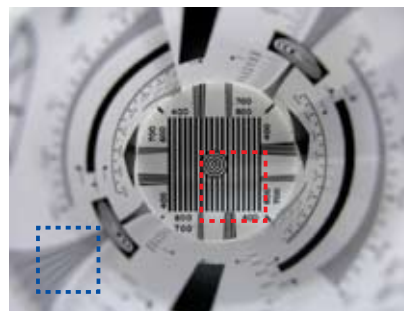


Image at center

Fisheye Lens



Standard wide angle lens

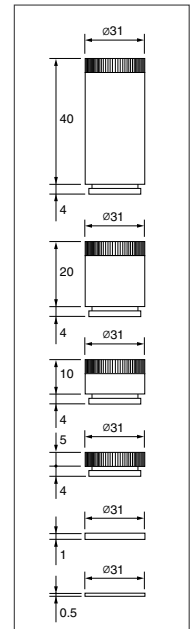


A standard wide angle lens has a focal point only at center, and the corners are usually out of focus. It is difficult to have the best performance in both the center and corner at the same time. However, H1328KP provides a vivid picture in both center and corners.





MODEL NO.	EX1.5CS	EX2CS	EX1.5C	EX2C
Description	1.5X Extender for CS-mount	2X Extender for CS-mount	1.5X Extender for C-mount	2X Extender for C-mount
Application	Attached between lens and camera - Makes focal length 1.5X	Attached between lens and camera - Makes focal length 2X	Attached between lens and camera - Makes focal length 1.5X	Attached between lens and camera - Makes focal length 2X



MODEL NO.	VM300	VM400	VM100
Description	View Finder	5mm Adapter Ring	Extension Tube Kit 40, 20, 10, 5, 1, 0.5mm
Application	Adjustable field of view - Helps determine required focal length	Attached between lens and camera - Adapts C-mount lens to CS-mount camera	Attached between lens and camera - Reduces minimum focusing distance

## 1. Calculation of Working Distance (WD)

Distance from lens to object (WD) is calculated by putting the size of a camera's imaging device, focal length and an object size into the following formula.

<Formula>  
 $WD = H1 + y \times f / y'$

[ Ex ]

When 2/3" camera with M2514-MP films an object whose vertical size is 120 mm.

f : 25 mm  
 H1 : 26.77mm  
 y : 120mm  
 y' : 6.6mm

Distance from lens to object=  
 $WD = 26.77 + 120 \times 25 / 6.6 = 481.32 \text{ mm}$

## 2. Calculation of Focal Length

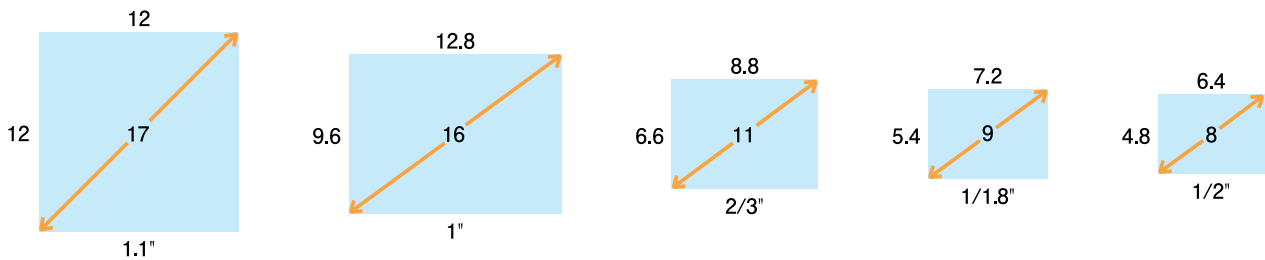
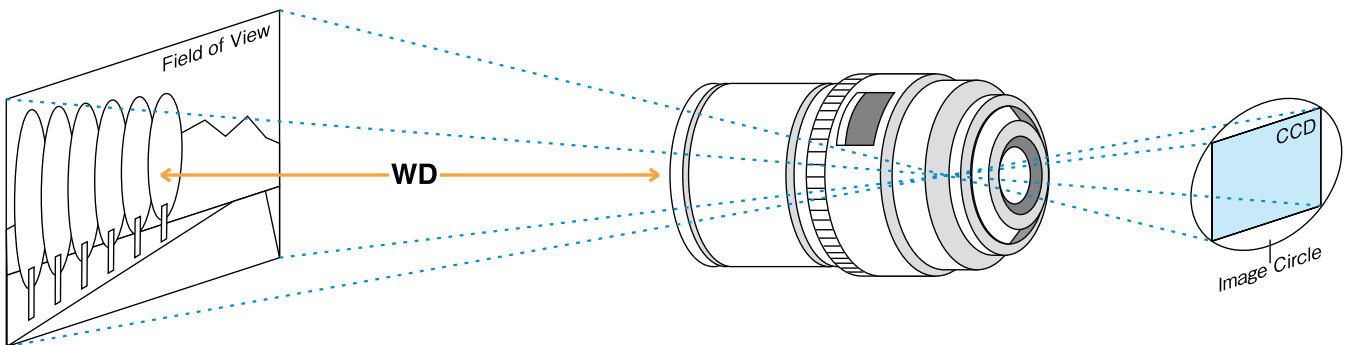
When size of a camera's imaging device, the object size and WD are fixed, focal length can be calculated by the following formula. You can select appropriate lens from the focal length.

<Formula>  
 $f = y' \times WD / y$

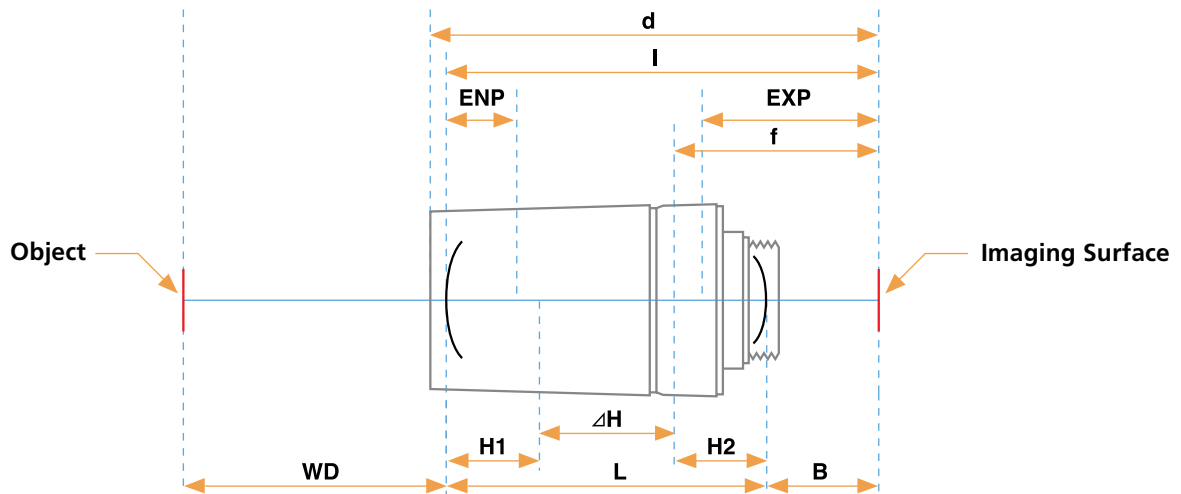
f = focal length of lens  
 WD = distance from lens to object  
 H1 : first principal point  
 y : vertical size of object  
 y' : vertical size of camera's imaging device

## CAMERA FORMAT

The size of camera's imaging device also affects the angle of view, with the smaller devices creating narrower angles of view when used on the same lens. The format of the lens, however is irrelevant to the angle of view, it merely needs to project an image which will cover the device, i.e.; the same format of the camera or larger. This also means that 1/3" cameras can utilize the entire range of lenses from 1/3" to 2/3", with a 1/3" 8mm lens giving the same angle as a 2/3" 8mm lens. The latter combination also provides increased resolution and picture quality as only the centre of the lens is being utilized, where the optics can be ground more accurately.



## OPTICAL DATA



Optical Data

		Focal Length	First Principal Point	Second Principal Point	L-(H1+H2)	Total Length	Back Focus	Optical Path Length	Entrance Pupil Diameter	Entrance Pupil Position	Exit Pupil Diameter	Exit Pupil Position	Distortion	Extension	Length
		f	H1	H2	$\Delta H$	L	B	l		ENP		EXP			d
<b>MEGAPIXEL MACRO ZOOM LENS</b>															
MLM-3XMP	Wide	30.22	30.22	-18.82	12.52	61.56	20.46	82.02	9.47	38.94	6.96	-10.82	0.36	-	97.53
	Tele	29.13	44.73	-37.76	-20.93	61.56	20.50	82.06	61.43	313.83	4.62	-10.82	2.27	-	97.53
<b>MEGAPIXEL VARI-FOCAL LENS</b>															
M3Z1228C-MP	Wide	12.00	36.23	2.71	19.77	53.30	14.71	68.01	4.29	25.63	36.76	-88.23	-2.56	-	70.53
	Tele	36.01	95.26	-22.57	-63.32	54.50	13.44	67.94	12.73	68.44	49.89	-127.65	3.51	-	70.53
<b>MEGAPIXEL FIXED FOCAL LENS</b>															
<b>5 MEGAPIXEL</b>															
M2518-MPW		25.00	27.40	-10.57	-10.91	27.06	13.97	41.03	13.90	20.84	18.84	-19.45	0.03	6.25	61.73
<b>3 MEGAPIXEL</b>															
M5028-MPV		50.00	7.38	-21.63	-1.21	27.80	27.71	55.51	17.85	21.26	13.97	-10.77	0.03	7.25	58.89
M3520-MPV		35.00	13.96	-16.33	-4.56	25.74	18.02	43.75	17.50	20.40	14.78	-10.89	0.01	7.25	50.87
M2518-MPV		25.00	27.40	-10.57	-9.70	28.26	13.79	42.05	13.90	20.84	18.84	-19.45	0.03	4.25	49.02
M1620-MPV		16.00	23.85	-0.62	3.47	27.93	14.68	42.61	8.02	15.75	16.24	-17.00	0.09	3.25	47.05
<b>MEGAPIXEL</b>															
M7528-MP		72.56	111.55	-63.11	-119.46	55.20	21.50	68.91	24.80	47.84	203.33	-585.50	0.19	15.54	71.03
M5018-MP2		48.00	22.14	-34.93	-16.20	40.86	13.08	53.94	25.94	52.85	15.82	-16.20	-0.29	4.77	55.63
M3514-MP		33.98	43.67	-19.75	-25.81	37.60	17.10	52.79	24.00	37.28	29.56	-27.62	-0.29	4.91	55.73
M2514-MP2		25.00	26.77	-11.90	-9.32	29.34	13.10	42.44	17.47	15.78	31.17	-31.50	-0.34	2.03	53.53
M1614-MP2		16.00	29.19	-2.90	-2.36	29.73	13.10	42.82	11.18	17.31	43.44	-49.05	-0.08	0.80	45.73
M1214-MP2		12.00	27.71	1.10	5.13	31.73	13.11	44.84	8.40	17.69	50.76	-59.45	0.11	0.44	45.73
M0814-MP2		8.31	22.47	4.83	16.09	33.73	13.14	46.87	5.81	15.36	40.39	-44.65	-0.11	0.21	45.73
H0514-MP2		5.08	20.25	5.73	35.98	50.50	10.84	61.34	3.55	14.99	102.99	158.24	-0.71	0.05	63.03
<b>TELECENTRIC LENS</b>															
TEC-M55		54.84	27.78	-23.48	-3.95	47.31	31.49	78.81	20.05	75.14	10.76	1.93	0.39	27.40	83.03
TEC-M55 with $\times 0.75$		41.17	51.63	-26.51	-14.13	64.01	14.66	78.67	19.80	73.77	12.87	-12.11	-0.88	27.40	83.03
TEC-M55 with $\times 2.0$		95.67	83.68	-70.81	-85.73	68.76	25.12	93.88	19.79	73.77	7.48	-11.30	0.45	27.40	83.03
<b>MACRO ZOOM LENS</b>															
MLH-10X (0.15m Wide)		18.80	91.31	2.92	4.33	92.71	23.36	116.07	3.75	83.50	6.42	-10.45	2.53	-	116.03
MLH-10X (0.15m Tele)		68.75	2.96	-102.80	-14.64	91.13	25.15	116.27	19.48	-264.94	6.69	-10.45	2.92	-	116.03

\* First Principal Point and Entrance Pupil Position are calculated from front lens

\* Second Principal Point and Exit Pupil Position are calculated from rear lens

## America

### CBC (AMERICA) CORP.

#### New York

55 Mall Drive,  
Commack, NY 11725, U.S.A.  
Tel : +1 800 422 6707  
Fax : +1 631 543 5426  
<http://www.computarganz.com>  
cctv@cbcamerica.com

### CBC (AMERICA) CORP.

#### California

20521 Earl Street,  
Torrance, CA 90503, U.S.A.  
Tel : +1 800 888 0131  
Fax : +1 310 793 1506  
<http://www.computarganz.com>  
cctv@cbcamerica.com

## Europe

### CBC (EUROPE) LTD.

#### London

7/8, Garrick Industrial Centre,  
Irving Way, London NW9 6AQ, U.K.  
Tel : +44 (0)20 8732 3300  
Fax : +44 (0)20 8202 3387  
<http://www.cbceurope.com>  
info@cbcuk.com

### CBC (EUROPE) LTD.

#### Milan

Via E. Majorana, 2  
20054-Nova Milanese, ITALY  
Tel : +39 0362 365079  
Fax : +39 0362 40012  
<http://www.cbceurope.it/cctv>  
sales@cbceurope.it

### CBC (DEUTSCHLAND) GmbH

#### Düsseldorf

Hansaallee 191  
D-40549 Düsseldorf, GERMANY  
Tel : +49 (0)211 53067 0  
Fax : +49 (0)211 53067 180  
<http://www.cbc-de.com>  
info@cbc-de.com

### CBC (Poland) Sp.zo.o.

#### Warszawa

Ul.Krasynskiego 41A  
01-755 Warszawa POLAND  
Tel : +48 (0)22 633 90 90  
Fax : +48 (0)22 633 90 60  
<http://www.cbcpoland.pl>  
info@cbcpoland.pl

### CBC Co., Ltd. MOSCOW REP OFFICE

#### Moscow

Bolshoy Strochenovsky per. 7,  
5th floor, Moscow, 115054, RUSSIA  
Tel: +7 495 710 8883  
Fax: +7 495 710 8884  
<http://www.cbc.ru>  
info@cbc.ru

## China

### CBC(Beijing) Trading CO.,LTD.

#### Beijing

Room B905-A, Tian Yuan Gang Center,  
No.C2 Dong San Huan Bei-Lu,  
Chaoyang District,  
Beijing, CHINA  
Tel : +86 10 6410 8081 Fax : +86 10 6410 8085  
<http://www.cbc-china.cn/10/>  
cbcliang@china.com

### CBC (SHANGHAI) TRADING CO., LTD.

#### Shanghai

Room 2703, Dawning Center, No.500  
HongBaoShi Road, Changning District, Shanghai,  
CHINA  
Tel : +86 21 3209 2626  
Fax : +86 21 3209 2814  
<http://www.cbc-china.cn/>  
support@cbcs.com.cn

### CBC (GUANGZHOU) Trading CO., LTD

#### Guangzhou

Room 1207, CITIC Plaza, No.233 Tian He North  
Road, Guangzhou City, Guangdong Province,  
CHINA  
Tel : +86 20 8752 0039  
Fax : +86 20 8752 0131  
<http://www.cbc-china.cn/>  
hua\_liang@gzcbc.com.cn

### CBC (H.K.) CO., LTD.

#### Hong Kong

Unit 2101, 21/F., Tower 6,  
China Hong Kong City, 33 Canton Road,  
Tsim Sha Tsui, Kowloon, Hong Kong, CHINA  
Tel : +852 2345 8686  
Fax : +852 2342 2908  
<http://www.cbc-china.cn/>  
larrywong@cbc.com.hk

## Asia

### CBC. S PTE LTD.

#### Singapore

15 Jalan Kilang Barat, #04-03  
Frontech Centre, SINGAPORE 159357  
Tel : +65 6275 1221  
Fax : +65 6275 0766  
enquiries@cbcs.com.sg

### CBC (Thailand) Co.,Ltd.

#### Bangkok

21st Floor, ITF Tower 140/48,  
Silom Road, Suriyawong,  
Bangrak, Bangkok 10500  
THAILAND  
Tel : +66 2231 6506  
Fax : +66 2231 6180  
cctvsales@cbcthai.com

### CBC Corporation (India) Private Limited

#### Mumbai

2F B Wing, Marwah Centre,  
Krishanlal Marwah Marg,  
Andheri East, Mumbai 400 072, INDIA  
Tel : +91 22 2857 9798  
Fax : +91 22 6649 1708  
enquiries.cbcindia@gmail.com

### CBC CO., LTD. JAKARTA REP OFFICE

#### Jakarta

MidPlaza II Building,12th Floor,  
Jl.Jend.Sudirman Kav 10-11,  
Jakarta Pusat 10220  
Tel : +62 21 570 7590  
Fax : +62 21 570 7591  
cbcrep@centrin.net.id

### T-CBC (TAIWAN) CO., LTD

#### Taiwan

Room D, 10th Floor, No.365 Fushing N. Rd.,  
Taipei, 10579, TAIWAN, R. O. C.  
Tel : +886 2 6600 8001  
Fax : +886 2 6600 5211  
<http://www.computar-com.tw/>  
cbc@computar.com.tw

### CBC Co. Middle East Branch Office

#### Dubai

Jebel Ali Free Zone  
P.O. Box: 262364 JAFZA View18  
23F, Dubai, UAE  
Tel : +971 4 886 5882  
Fax : +971 4 886 5883  
<http://www.cbceurope.com/>  
nawa@cbcme.ae



#### Head Quarters

Electronic Technology Company Image & Information Technology Division  
2-15-13, Tsukishima, Chuo-ku,  
Tokyo 104-0052, Japan  
Tel : +81 (0)3 3536 4678 Fax : +81 (0)3 3536 4841  
<http://www.cbc.co.jp>

Tokyo HQ Registered



Tokyo HQ Registered



[www.computar.jp](http://www.computar.jp)  
[www.cbc.co.jp](http://www.cbc.co.jp)